

## 3.202 Metrology in Electrochemistry

### Motivation

#### controlled-current coulometry

- is a primary method for amount of substance
- offers a direct link to the SI
- is useful for assay of reference materials

### Aim

Determination of amount content of HCl for the primary method of pH

### How to realize?

The basis:

M. Faraday (1834): „Chemical effects of electric current are directly proportional to the absolute quantity of electricity, which passes through the system“

$$n = \frac{Q}{z \cdot F} = \frac{\int I \cdot dt}{z \cdot F}$$

where

- $n$  : amount of substance
- $Q$  : electric charge
- $t$  : time
- $z$  : charge number
- $F$  : Faraday constant

### Multilateral comparison

#### Pilot study CCQM-P19

Coulometric assay of HCl amount content. Dependence of the acid concentration on storage time was observed. The figure shows the H<sup>+</sup> assay recalculated to 3 March 2000 as measurement date [1].

[1] M. Mariassy, CCQM working paper on high-accuracy controlled-current coulometry

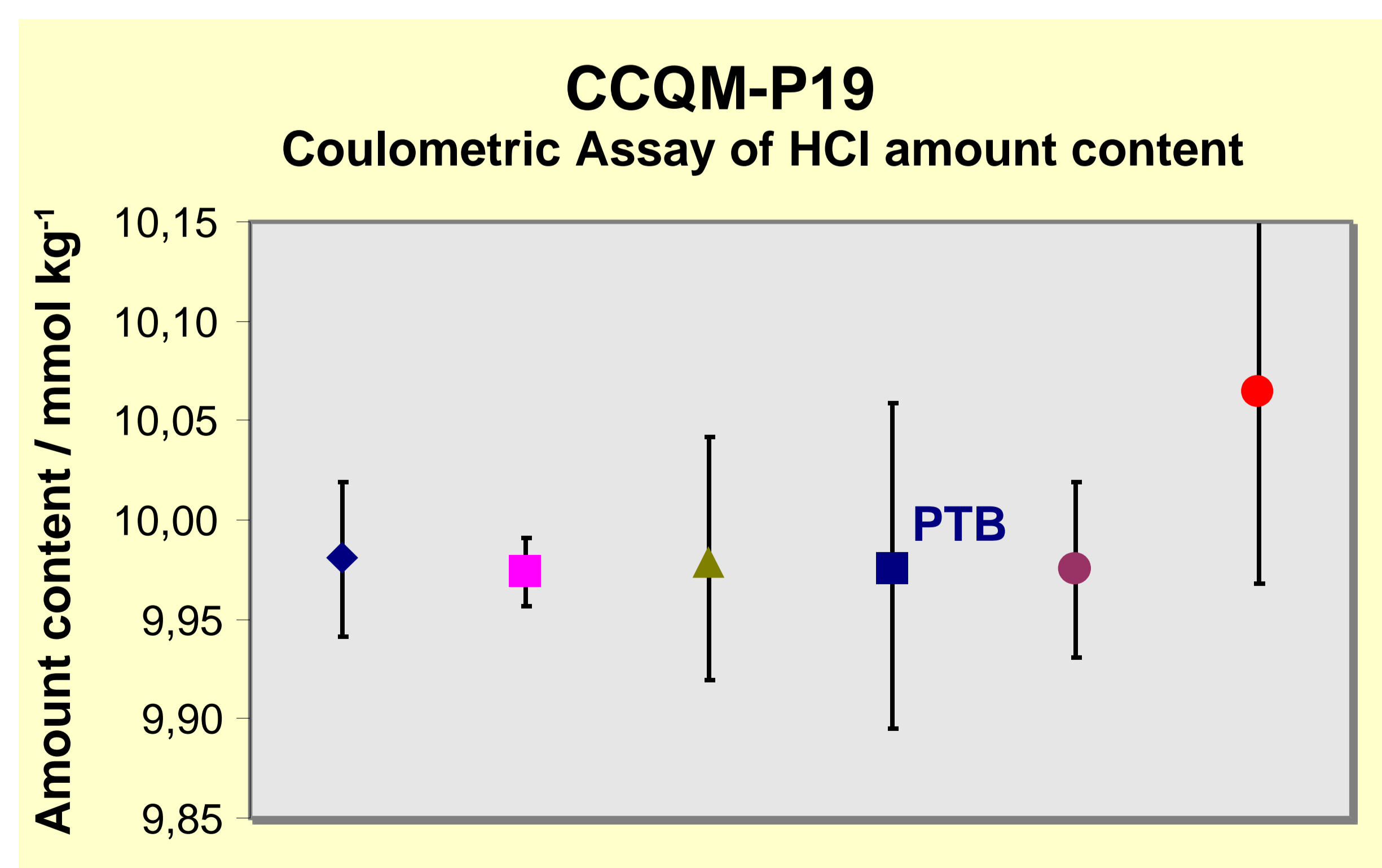

### The Procedure

Assay of 0,01 mol kg<sup>-1</sup> HCl

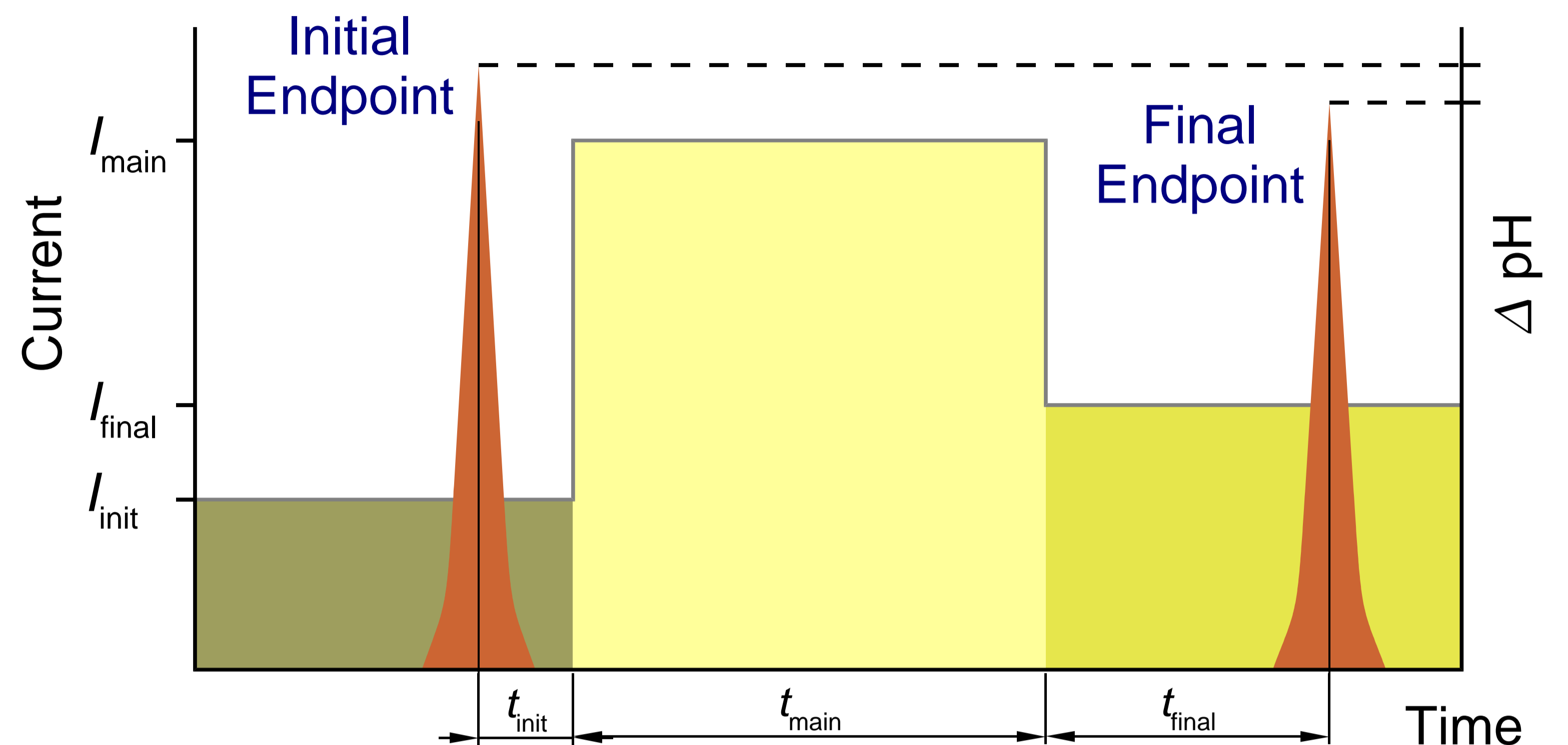

$$v = \frac{1}{z \cdot F \cdot m} (I_{init} \cdot t_{init} + I_{main} \cdot t_{main} + I_{final} \cdot t_{final})$$

$v$  amount content  
 $m$  sample mass

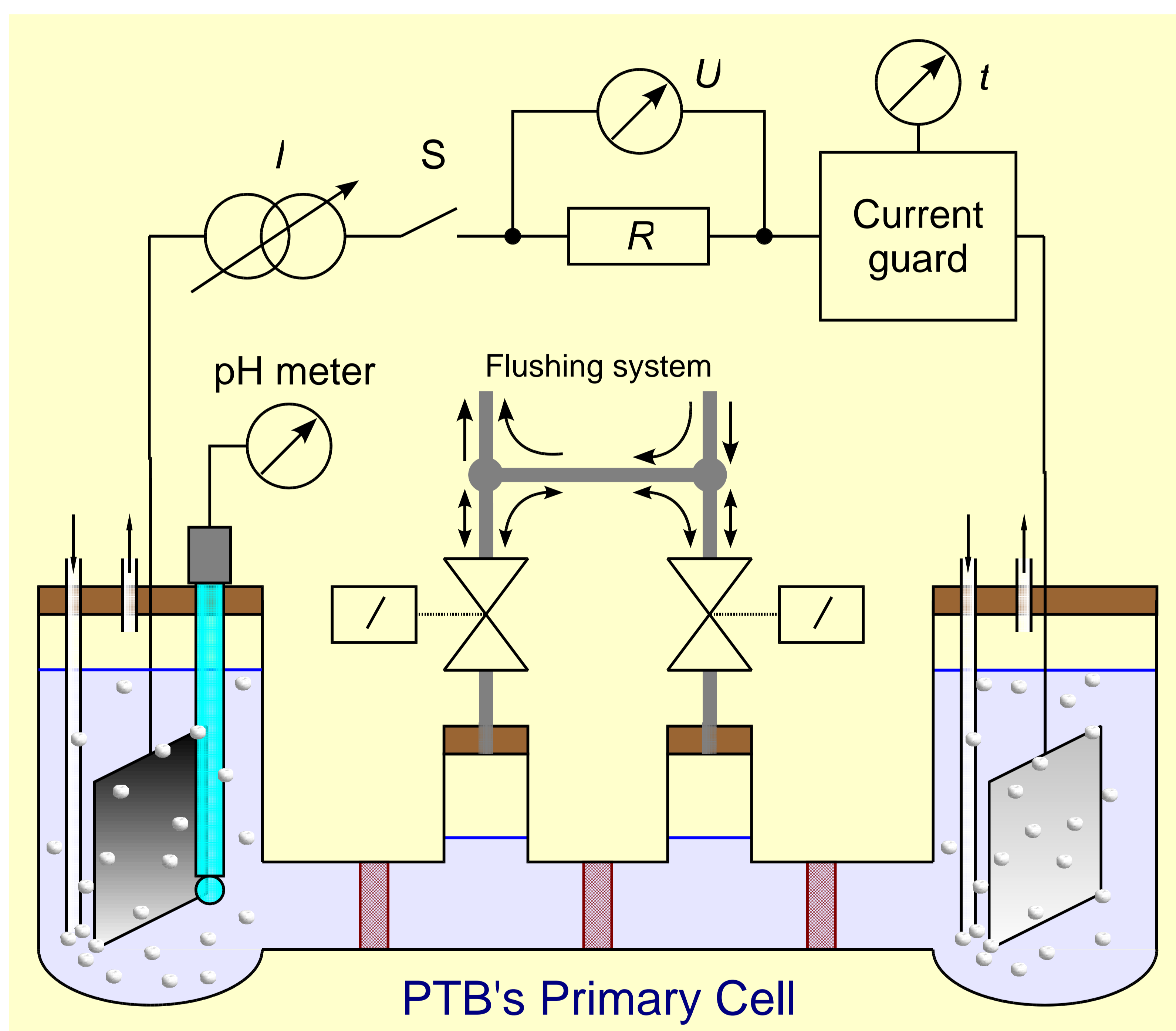

controlled-current coulometry :  $I = \text{constant}$

### Future work

Extension to determination of chloride content in reference materials for conductivity and clinical chemistry in cooperation with the SMU (Slovakia)