

A UNIQUE FLUID DIVERTER DESIGN FOR WATER FLOW CALIBRATION FACILITIES

W. Poeschel, R. Engel, D. Dopheide

Physikalisch-Technische Bundesanstalt (PTB) Braunschweig, Germany

H. J. Baade, Droege, Baade + Partner, Salzgitter-Thiede, Germany

H. J. Kecke, R. Praetor, N. Weist, E. Kurras

Otto-von-Guericke-Universität Magdeburg, Germany

Abstract: A special fluid flow diverter was developed and tested for the new water flow standard facility which is under construction now at PTB Braunschweig. It offers several new features and properties for improving the accuracy, e. g. variable rectangular nozzle, CFD designed influx pipe section and high precision electromechanical switching device. The paper describes design and test results of a first prototype in a water flow circuit.

Keywords: Flow measurement, Test facility, Fluid diverter, Accuracy.

1 INTRODUCTION

Fluid flow diverters are essential elements in modern liquid flow measurement facilities using the dynamic test method (flying start and stop of meter under test read out) by determining the liquid quantity using static weighing or static volume standard measurement. The effect of errors of the diverter, especially in high accuracy calibration facilities, is a critical part of the total measurement uncertainty. A proper and careful design of the fluid diverter is therefore one of the main tasks for planning and constructing of a high accuracy liquid flow measurement facility.

At PTB Braunschweig such a test facility is under construction now [1]. It is intended to establish the National Primary Standard for water flow measurement in Germany with a total expanded uncertainty (2σ -value) of 0.02 %. A special fluid flow diverter design was developed for this standard facility, offering several new features and properties. The paper describes in detail the accuracy requirements, the design and test results with a first prototype of the new diverter in a water flow circuit.

2 FUNCTION AND OPERATION OF THE DIVERTER

Fluid diverters in flow measurement test facilities are used to divert the liquid flow into a weighing or measuring tank when starting a measurement and to switch it back at the end of the measurement. Figure 1 shows a scheme of a gravimetric water test rig with a diverter (7) above a weigh tank (8) placed on a balance. The diverter is part of the liquid flow circuit comprising a storage tank (4), a pump system (1), a constant head tank (2) for stabilizing the flow rate, the test section (5) with the meter under test (6) and, following the diverter, the weigh tank and a by-pass pipe (9).

A measurement for calibrating a flow meter is carried out by the following steps (see Figure 1): The desired flow rate is presupposed and the process control system fits the test plant to the point of operation. The pumps (1) are conveying the water in a closed circuit consisting of a pipe system to the constant head tank (2) with a defined rate of overflow via a weir (3) back to the storage tank (4). The main flow passes the test section (5) including a control valve (10) and the flow meter under investigation (6). In this way constant hydrostatic head and constant flow rate is achieved in the test section. The system is operated until steady state is obtained and all process variables are lying within permitted limits. During this time the water flow is returned by the diverter (7) to the storage tank.

To start a measurement the diverter switches the water stream into the weigh tank (8) and releases synchronously the readings. After a presupposed period of time or if the weigh tank is filled to a given limit, the diverter switches the water stream back to the bypass (9), leading to the storage tank, and stops synchronously the readings of the time measurement and of the meter under test. The test result is calculated by the difference of flow meter readings compared with the weighed mass of water in

the weigh tank, converted with density of the water. All these steps are performed automatically by the process control system in real time.

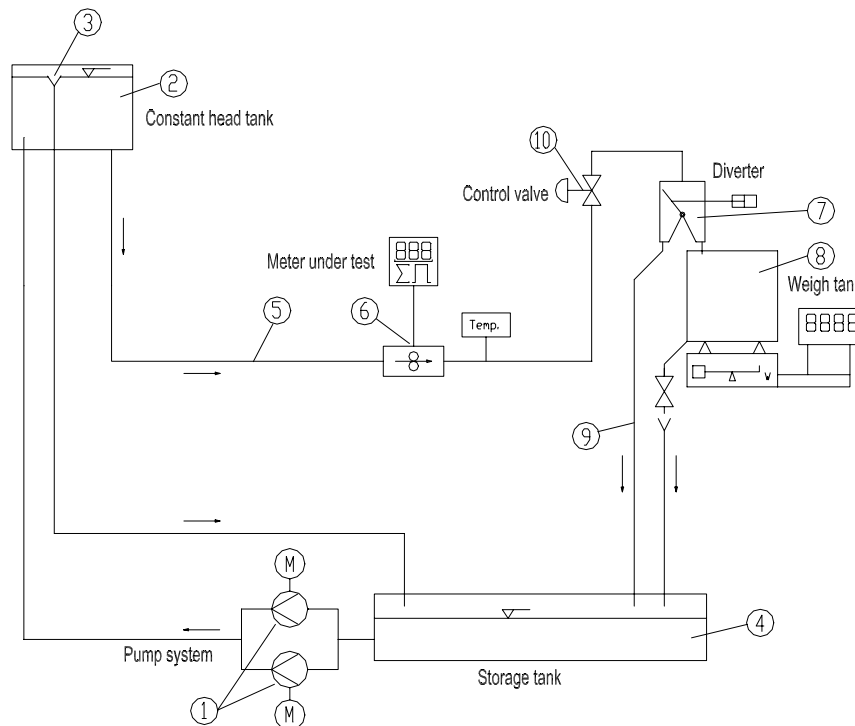

Figure. 1. Gravimetric water flow test facility

3 REQUIREMENTS FOR THE DIVERTER DESIGN

Except of the mass or volume standard, the diverter is the most important component of a flow test facility under the point of view of its total measurement accuracy. Therefore high demands are made on the fluid diverter (Table 1).

Table 1. Requirements to the diverter

Flow rate range	1 : 100
Nozzle	variable rectangular cross-sectional flow area
Variation of nozzle's centre line at different widths	< 0.2 mm
Variation of jet's centre line at different widths	< 1 mm
Mean velocity of the jet	0.5 ... 5 m/s
Flow profile of the jet relative deviation from symmetry	approximately symmetrical < 2 %
Angle of diverting edge	< 7.5°
Speed of diverting edge	0.5 ... 1 m/s
Jet transition time for small-size diverter for large-size diverter	< 50 ms < 150 ms
Reproducibility of transition time	0.2 ms
Resolution of start/stop signal	0.05 ms
Standard uncertainty of the diverter	0.004 %

3.1 General and Flow Mechanical Requirements

The diverter is to work properly within a flow rate range of 1:100. The diversion of the flow must not have any reaction on the water flow. Therefore, an open system with a free water jet is preferred. The nozzle design has to guarantee that within the whole flow rate range a full, not splashing water jet is formed with a nearly rectangular cross-sectional area. To achieve this goal, a variable cross section of the nozzle's outlet is necessary. Besides the jet stream the diverter has to be absolutely tight. Windows for observing and checking the jet quality and the tightness should be provided.

The quantities in Equation (1) are defined as follows:

C_{Div} – relative correction factor of the diverter, T_M - measuring time, t'_s , t''_s - time from the start (respectively stop) signal to the time when the diverting edge is passing the centre line of the jet, \bar{t}_s - mean of t'_s and t''_s , Q' ; Q'' – flow rate at the begin and, respectively, at the end of the measurement, \bar{Q} – mean flow rate, Q_{left} ; Q_{right} – part of flow rate left and, respectively, right from the centre line of the jet, \bar{T}_{jet} - average jet transition time.

The correction factor of the diverter C_{Div} comprises three components, represented by the three terms in Equation (1). The first, considering differences of the times t'_s and t''_s , is the main component and depends on the synchronization accuracy of the start and stop signals symmetrically to the jet's centre line. Because of the fractional imperfection of the geometry of the jet, the position of its centre line has also an uncertainty. Therefore limits for the alignment error smaller than ± 1 mm seem to be not realistic. This corresponds to relative error limits of $\pm 6 \cdot 10^{-5}$ (measuring times not smaller than 50 s and speed of the diverting edge > 0.7 m/s assumed). When dividing this value by $\sqrt{3}$, the standard uncertainty component for this influence of $3.5 \cdot 10^{-5}$ is obtained (according to the ISO-Guide to the expression of uncertainty in measurement [3], equal distribution of the errors assumed).

The second term in Equation (1) considers differences of the flow rates at the begin and the end of the measurement. This error is mostly negligible and e. g. smaller than $1 \cdot 10^{-6}$ when $t_s < 5$ ms (start and stop signal close to the jet centre), $T_M > 30$ s and $(Q' - Q'') / \bar{Q} < 5 \cdot 10^{-3}$. The third term describes the influence of an unsymmetrical flow velocity profile across the jet. This error is smaller than $\pm 3 \cdot 10^{-5}$ when $T_M > 50$ s, $\bar{T}_{jet} < 0.15$ s and $(Q_{left} - Q_{right}) / \bar{Q} < 2 \cdot 10^{-2}$ (corresponding standard uncertainty component $1.7 \cdot 10^{-5}$). Thus the standard uncertainty of the diverter u_{Div} is expected to be:

$$u_{Div} = \sqrt{3.5^2 + 0.1^2 + 1.7^2} \cdot 10^{-5} = 3.9 \cdot 10^{-5} < 4 \cdot 10^{-5}$$

Table 1 gives a survey of the main requirements to the diverter design.

4 SET UP OF A NEW DIVERTER PROTOTYPE

The mentioned demands are realized by the developed diverter design. A schematic drawing is shown in Figure 3. The diverter is depicted as a complete system including both the switch over device with rectangular nozzle (1) and the water feeding pipe section (2). The function of the water feeding pipe is to change the direction of flow from the horizontal test pipe section including the flow meter under test into a vertical rising pipe leading to the diverter downstream in a hydraulic optimized manner, see paragraph 5. The switch over device comprises the nozzle (3) with variable cross section forming a rectangular water jet and a bifurcated conduit (11) pivoted on a horizontal axis (5).

In order to obtain a "good" rectangular stream with sharp outlined contour without spraying and with a smooth surface, stream outlet velocity always has to be within certain limits. To achieve a large flow rate range, therefore, it is necessary to adapt the outlet section (3) to the point of operation. This can be done by moving the long side plates of the nozzle (12), which are made of high tensile plastic and which are flexible in a solid joint. The adjustment of the gap width is done continuously by an electric drive and worm gear screw jacks without backlash (4). The permissible range of adjustment is checked by limit switches. The front plates of the nozzle are consisting of transparent plates to observe the flow and to carry out laser-based velocity profile measurements. The sealing between the movable parts of the nozzle and the front plates is made solely by contacting the materials with initial stress and manufacturing with minimum restricted tolerances.

The free jet stream leaving the nozzle passes the main constituent of the diverter, a bifurcated conduit (11) including the baffle plate with a sharpened diverting edge (6). This component is designed in order to avoid spraying and other water loss, e.g. crawling of a water vortex backwards over the diverting edge. These demands are satisfied by limiting the angle of impact of the water jet to the baffle plate at all points of operating to less than 7.5° and by applying stainless steel, very even with a roughness of surfaces coming in contact with water less $6.3 \mu\text{m}$. The bifurcated conduit is switched over by a partial rotation round the horizontal axis, actuated by two synchronous operated linear drives (7), which are coupled by a shaft with an electric drive. This drive is able to perform the switch-process exactly in a presupposed time and velocity both by accelerating and by slowing down in either directions. In this way, the water stream is lead in a strongly controlled manner either into the bypass

pipe (8, 10) leading to the storage tank or directly into the weigh tank (9). The path of motion and the position of the baffle plate are detected by metering the angle of rotation with an incremental transmitter. The permissible range of rotation is checked by limit switches.

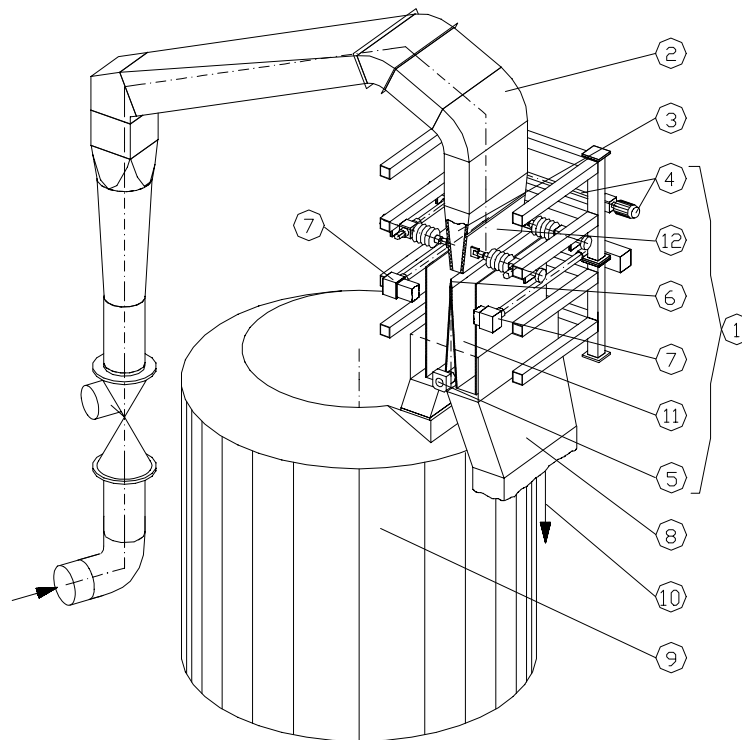

Figure 3. Diverter prototype with feeding pipe section and weigh tank

To achieve best results, the prototype is constructed with respect to a strong symmetric design. All parts except nozzle plates are made from stainless steel.

5 DESIGN OF THE DIVERTER FEEDING PIPE SECTION

The final goal of designing the feeding pipe section of the diverter is to achieve a flat, approximately symmetrical velocity profile across the jet width. The basic shape of the feeding section is given by its fitting into the test facility and considering spatial restrictions due to the height of the building in which the calibration facility is erected. The flow direction has to change from the horizontal test section (including the flowmeter under test) into a vertical rising pipe and then after three elbows downstream to the diverter nozzle. Along the same line the cross section has to change itself from circular to rectangular area.

The diverter should reach a flow rate range of 1:100. As a minimum of water jet velocity 0.5 m/s was set to ensure jet stability. On the other hand the velocity should not exceed 5 m/s to prevent splashing and spraying. Therefore a variability of the nozzle width of 1:10 is necessary. It is well known that a symmetrical profile can be achieved by the contraction of the flow. Therefore a minimum area ratio of the nozzle's inlet and outlet of 2:1 was set.

For the diverter prototype a nominal diameter for the inlet pipe of 150 mm was chosen and a flow rate range from 3 to 320 m³/h. The nozzle length is 450 mm. The width at the nozzle's inlet is 80 mm and ranges at its outlet from 3.7 mm to 40 mm. Figure 4 shows the range of operation for the diverter prototype.

For designing and optimizing the feeding pipe section a lot of numeric calculations of flow and pressure fields were carried out by use of the CFD program CFX-TASCflow. Several variants with different elbow radii, cross sections and vanes were taken into consideration. It must be ensured that no flow separation appears and the diffuser criterion is met. Furthermore, the influence of Reynolds number, the minimum operating, pressure and flow conditions at the highest point were included in the investigations.

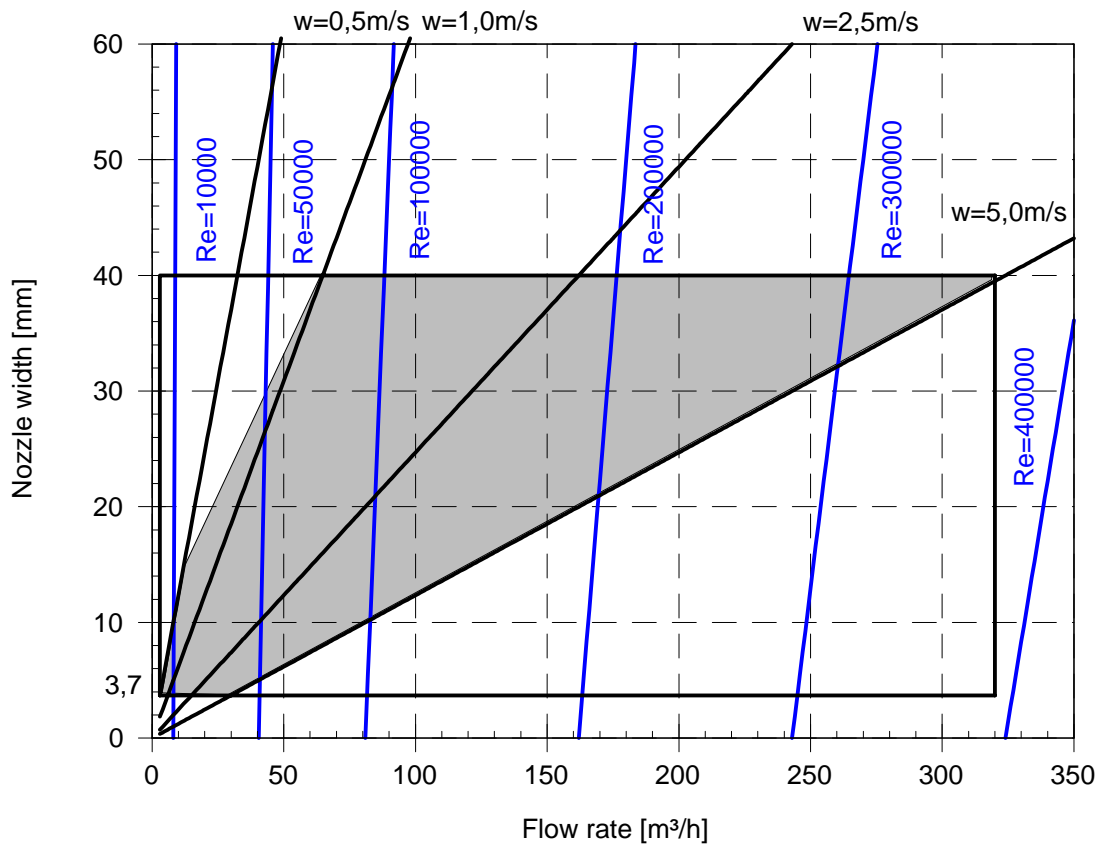

Figure 4. Operating field of a DN 150 mm diverter

Figure 5 shows the chosen shape of the diverter feeding pipe and an example of a calculated velocity distribution is presented in Figure 6.

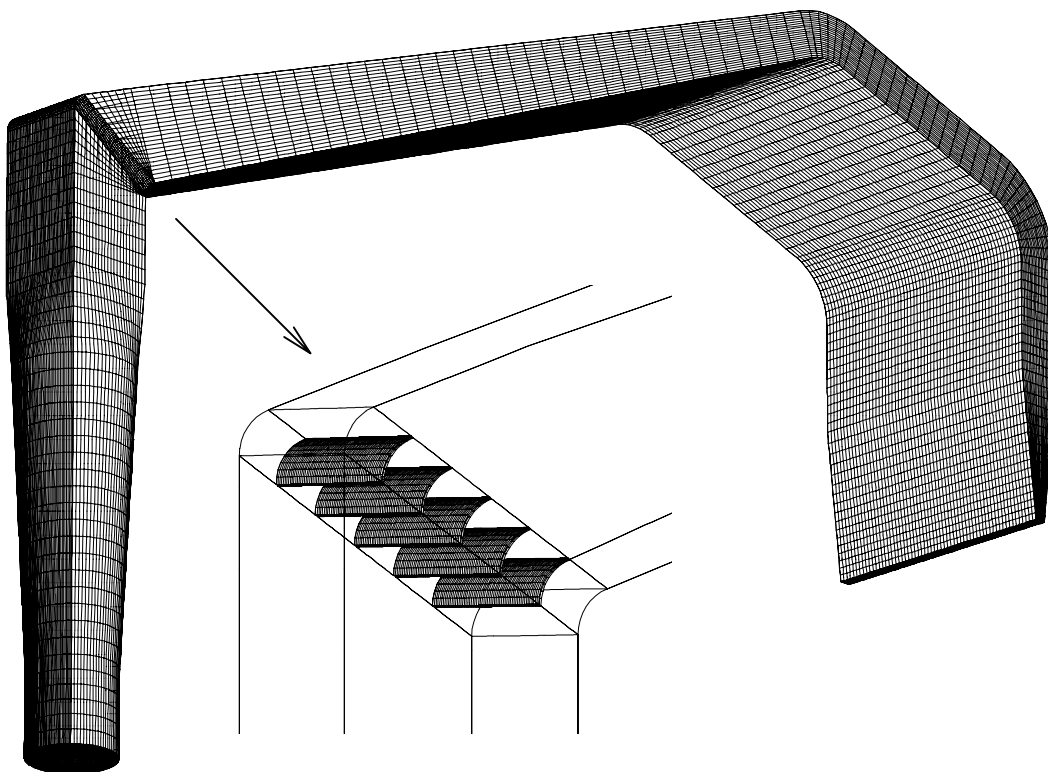

Figure 5. Grid geometry used for the numeric simulations (diverter feeding pipe section)

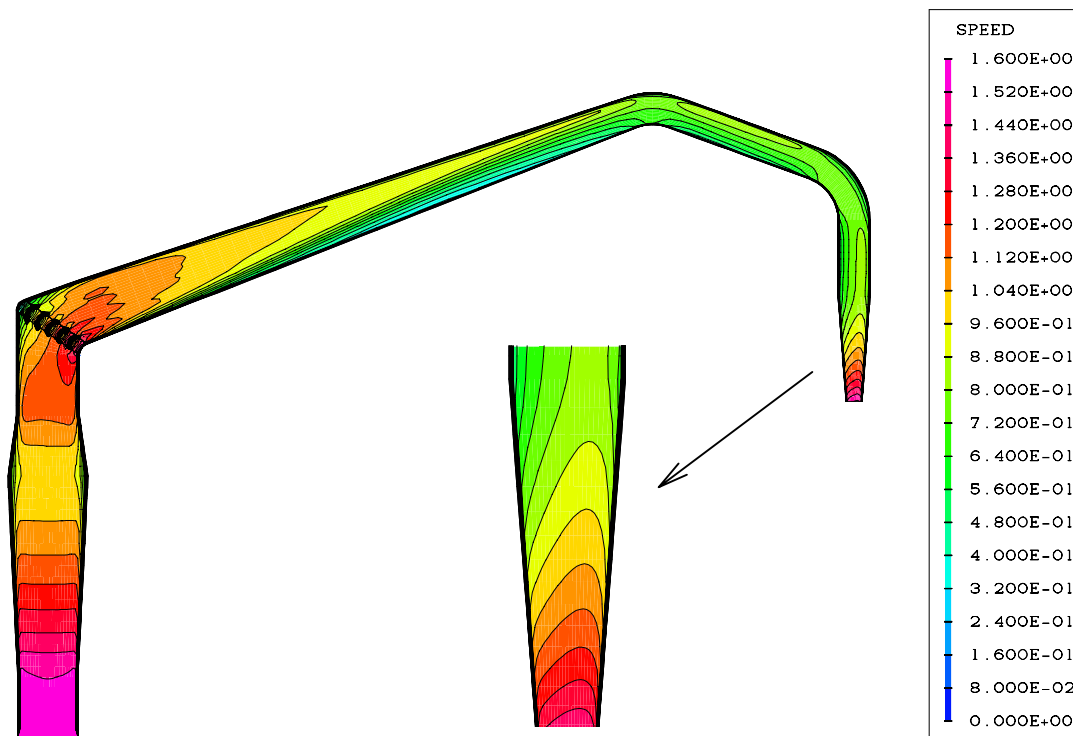

Figure 6. Calculated velocity distribution in the centre cross section (nozzle width: 40 mm, flow rate: 97 m³/h)

As a result of the theoretical investigations, the unsymmetry $(Q_{left} - Q_{right}) / \bar{Q}$ of the diverter jet can be expected between 0.04 % (for 3 m³/h) and 1.8 % (for 320 m³/h) and thus is smaller than the given limit of 2 %.

6 TEST OF THE DIVERTER PROTOTYPE

The mechanical and fluid mechanical performance of the diverter prototype was tested in a water circuit up to 100 m³/h. Figure 7 shows a photo of the test installation (diverter and inlet pipe section), Figure 8 a photo of the nozzle and the water jet. In addition to a general function test the following investigations and observations were made.

Jet quality: To fill the diverter pipe system, it takes a certain time and a minimum flow velocity of the water flow through the diverter and the nozzle outlet to stabilize the state of flow. This process can be observed through the transparent front plates of the nozzle and the windows at the top of the inlet pipe section. The needed velocity can be set by varying the nozzle width. After the flow is free from air bubbles the water jet has a good homogeneous flow profile up to about 5 m/s (without splashing and spraying). The minimum velocity for obtaining a full and stable jet depends on the nozzle width. It is 0.8 m/s at a width of 40 mm and goes down to 0.5 m/s at 4 mm width. The best jet quality (clear jet with smooth surfaces) is obtained at Reynolds numbers between 10³ and 10⁵ relating to velocities up to 1.5 m/s.

Adjustability of nozzle width: The drive for changing the nozzle width allows an accurate adjustment of the nozzle's side plates without problems. The nozzle was absolutely tight. The reproducibility of the side plate positions was better than 0.1 mm. So the variation of the nozzle's center line can be expected to be smaller than the required 0.2 mm.

Speed characteristic of diversion plate: The precision switching drive allows a speed controlled movement of the jet diverting edge with constant speed through the jet up to 1 m/s. The course of speed and its constancy were examined by using a high resolution pulse encoder. The results are described in a separate paper [4].

Start and stop signal: The adjustment of the start and stop signal will be done not mechanically but more precisely electronically by means of the high resolution pulse encoder. This method and its advantages are described in [4].



Figure 7. Test installation of the DN 150 mm diverter prototype

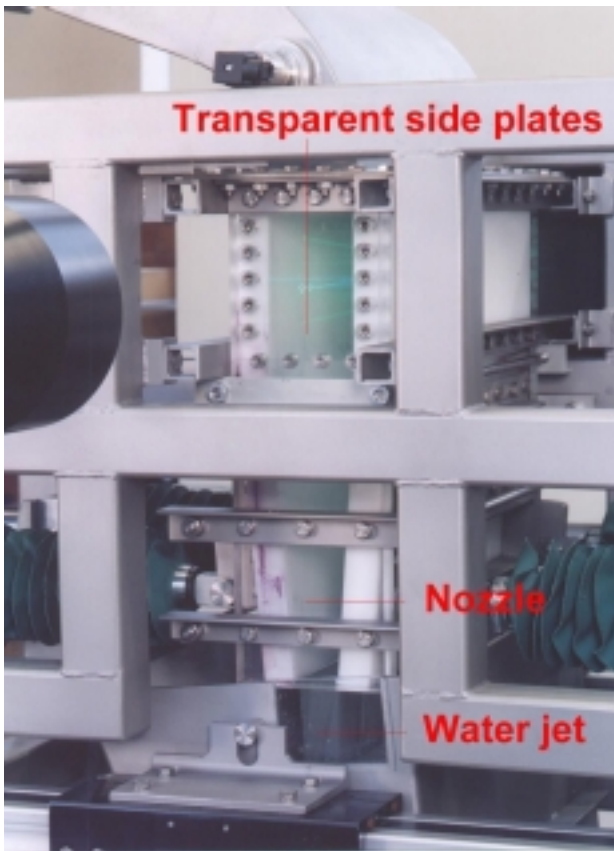

Figure 8. Diverter nozzle with movable side plates and rectangular cross-sectional water jet

Velocity profile of the water jet: The velocity profiles of the water flow at the outlet of the nozzle were measured through the transparent front plates of the nozzle by using a laser anemometer. Figure 9 shows the results of measurements at three different nozzle width settings in comparison to the results of computer simulation.

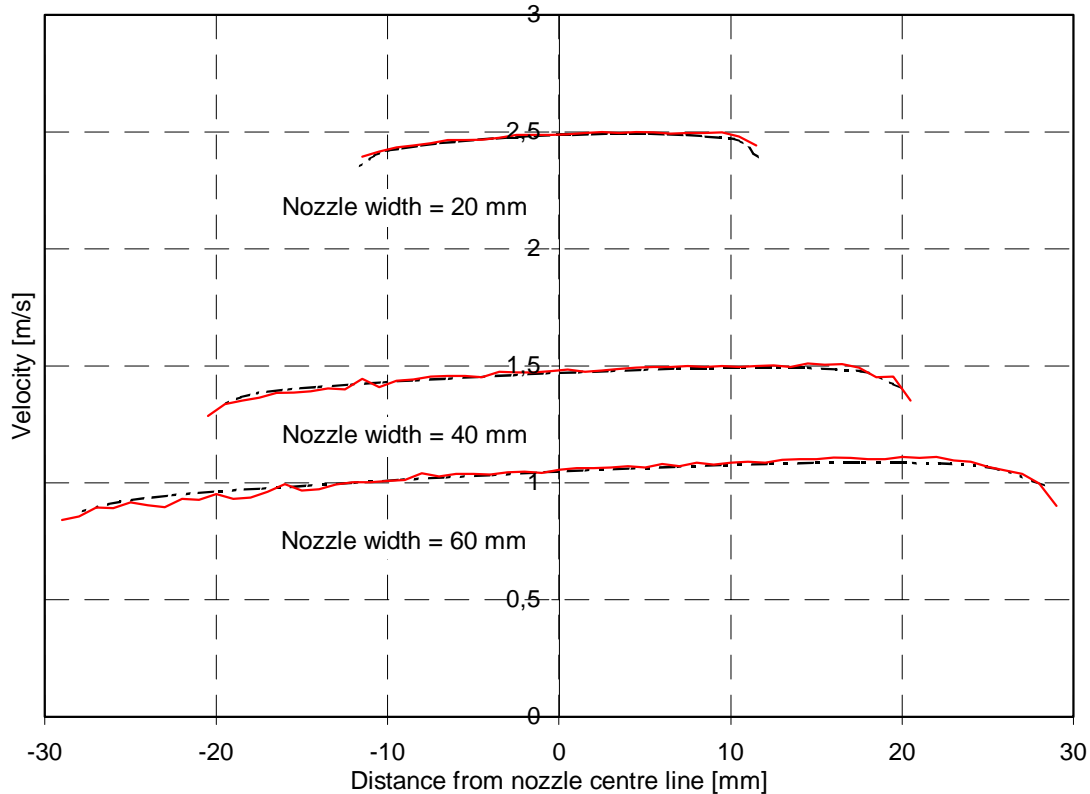

Figure 9. Fluid velocity profile near diverter's nozzle outlet at 3 different nozzle width settings, — measurement, - - - simulation

It can be observed that measured and calculated curves are in a very good agreement. That means, the final result of the flow investigations (unsymmetry of flow profile smaller than 2 %) is confirmed by experimental results.

REFERENCES

- [1] W. Poeschel, R. Engel, The Concept of a New Primary Standard for Liquid Flow Measurement at PTB Braunschweig. *Proceedings, the 9th International Conference on Flow Measurement FLOMEKO'98*, p. 7-12, Lund, Sweden, 1998.
- [2] PTB report (unpublished): "*Hydrodynamisches Prüffeld*" (Hydrodynamic test facility, Chapter 4: Uncertainty budget and requirements to attain the claimed measurement uncertainty), PTB, 1998, Braunschweig (Germany)
- [3] ISO International Standard Organization: "*Guide to the expression of uncertainty in measurement*", 1992
- [4] R. Engel, U. Klages, A Novel Approach to Improve Diverter Performance in Liquid Flow Calibration Facilities, *Paper*, FLOMEKO 2000 Conference, Salvador, Brazil, June 2000.

AUTHORS:

Dr.-Ing. Walter Poeschel, Dr.-Ing Rainer Engel, Direktor & Professor Dr. Dietrich Dopheide, Fluid Mechanics Division, Physikalisch-Technische Bundesanstalt, PTB, Bundesallee 100, D-38116 Braunschweig, Germany, phone +49-531-592 1320, +49-531-592 1363, +49-531-592 1300, E-mail: walter.poeschel@ptb.de, rainer.engel@ptb.de, dietrich.dopheide@ptb.de

Dr.-Ing. Hans Joachim Baade, DRÖGE, BAADE + PARTNER (Consulting Engineers), Matthias-Claudius-Str. 5, D-38239 Salzgitter, Germany, phone +49-5341-29400. E-mail: Baade@d-b-p.de

Prof. Dr.-Ing. Dr. h.c. Hans Joachim Kecke, Dr.-Ing. Ralf Praetor, Institut für Strömungstechnik und Thermodynamik, Otto-von-Guericke-Universität Magdeburg, D-39106 Magdeburg, Germany, phone +49-391-67 18569, +49-391-67 12336, E-mail: hans-joachim.kecke@vst.uni-magdeburg.de, ralf.praetor@vst.uni-magdeburg.de

Dr.-Ing. Norbert Weist, Dipl.-Ing. Erdmann Kurras, Institut für Mechatronik und Antriebstechnik, IMAT - Otto-von-Guericke-Universität Magdeburg, D-39106 Magdeburg, Germany, phone +49-391-67 18606. E-mail: norbert.weist@mb.uni-magdeburg.de, erdmann.kurras@mb.uni-magdeburg.de